

RCC-8A+/9A+ **USER MANUAL**

Congratulations on the purchase of RCC-8A+/9A+ Electronic Refrigerant Processor

This is one of the best investment you have made for your workshop. Due to that the company continues research and development and the joint effort of design, electronic and mechanical engineers including our sales representatives, air-conditioning manufactures and discussing the needs and issues of various workshop operators, in various countries around the world, we have manufactured one of the most user friendly, efficient and smart refrigerant processor. The RCC-8A+/9A+ refrigerant processor incorporates electronic intelligent using microprocessor platform. This system will help your technicians in achieving their best capability in diagnosing and rectifying air-conditioning issues, thus increasing productivity and profitability for your business. Our company would like to work with you as partners in your business to help you achieve maximum return on your investment, so please do not hesitate to contact us or our distributors, if we can be of any further assistance in relation to this equipment or any air-conditioning related issues. We are here to help you achieve your goal.

INDEX

Specifications.....	2
General safety guide.....	3
Component identification.....	4
Function description.....	6
Preparations before operation.....	7
1. Unlock tank load cell.....	7
2. Tank fill.....	7
3. Non-condensable purge.....	7
Operating procedure.....	8
Recovery function.....	8
Evacuation function.....	8
Oil injection function.....	8
Refrigerant charging function.....	9
Tank fill.....	9
Flushing function.....	10
Automatic function mode.....	10
System Setting.....	11
Calibration.....	11
Database:	11
Unit settings:	11
Empty container weight set:.....	11
Component test:	11
Caring for your equipment.....	12
Update.....	13
Maintenance reminding.....	14
Packing list.....	15

Specifications

- Dimension: Package 720*670*1190mm; Unpacked machine 630*560*1075mm³
- Input power: AC220V±10%~50/60Hz, or AC110V±10%~60Hz
- Compressor power: 3/8HP
- Average gas state refrigerant recovery speed: 0.25Kg/min.
- Recovery rate: 96%.
- Pressurization to speed up old oil discharge.
- Vacuum pump capacity: 60L/min.
- Individualized filter-drier capacity: 600ml
- Accuracy of gas cylinder load cell: ±10g
- Accuracy of oil bottle load cell: ±5g
- Gas cylinder capacity: 10KG
- New oil bottle capacity: 250ml
- Used oil bottle capacity: 400ml
- Condenser and cooling fan included.
- Max. Pressure: 20bar
- Charge speed: 2Kg/Min(max.)
- LCD display: 4.3-inch ,TFT full color
- High pressure gauge range: -1bar~40bar
- Low pressure gauge range: -1bar~22bar
- A/C database included, update through USB port.
- Automatic service reminding. The equipment provides 600 operations totally (each recovery or vacuum counts for one operation, and flush counts for 3 operations) between regular maintenance, When 600 operations have been made the machine automatically reminds to call distributor for maintenance.
- Thermal printer
- Heater band
- *Optional: Automatic air purge*
- *Optional: Vacuum leak test*
- *Optional: 120L/Min vacuum pump*
- *Optional: UV dye injection*
- *Optional: HFO-1234yf, difference including non-sparkle vacuum pump, 30 seconds pre-ventilation before machine is switched on, HFO-1234yf couplers etc..*

General safety guide

- **This equipment must only be operated by qualified technicians.**
- Read instruction manual carefully before operating this equipment. If there is anything you do not fully understand, please contact your distributor or manufacturer. We like to help.
- The refrigerant storage cylinder contains liquid refrigerant under high pressure. Overfilling of the storage cylinder may cause violent explosion. Do not disable the overfill safety protection of this machine. Always keep the cylinder on the load cell platform whenever the machine is operating.
- Only use cylinder which is supplied with this equipment or recommended by the manufacturer.
- Always use this machine in a well-ventilated area, avoid inhaling refrigerant and/or oil vapors, always read material safety instructions of refrigerant and oil packaging, for related warning and care.
- Always switch off the machine and disconnect power cable before removing any covers or servicing this machine, to avoid electric shock which can be fatal.
- Never use compressed air to test for leaks on vehicle or this equipment!
- Wear safety goggles and gloves, to protect eyes and skin from contact with refrigerant. Liquid refrigerant when it comes in contact with the human skin or eyes will cause frostbite and/or blindness. If accidental contact is made with eyes or skin, wash the affected area with plenty of fresh water immediately and contact a doctor if required.
- Avoid using the machine in very hot or flammable areas.
- Store the machine in a well ventilated cool area when not in use.
- Avoid using extension power cable thinner than 1.5mm² (10amp current carrying capacity).
- Keep gasoline or other flammable substances away from the equipment.
- ***For 1234yf machine, once a leak is detected in the unit, switch off the equipment by pressing the Emergency stop button and contact your distributor or service dealer.***

Component identification

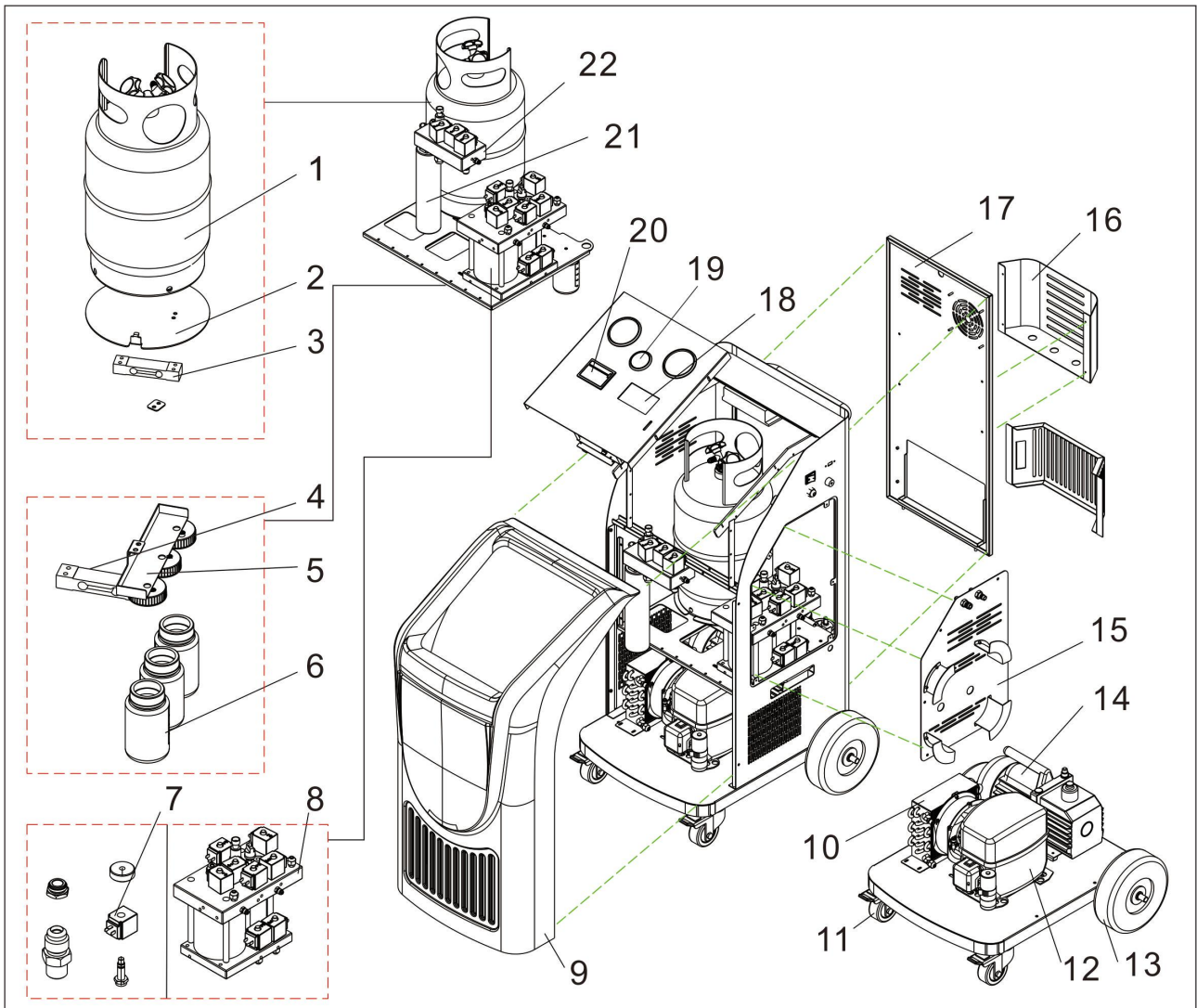

1) Refrigerant gas cylinder	2) Refrigerant gas cylinder support plate	3) Refrigerant gas cylinder load cell
4) Oil bottle load cell	5) Oil bottle support	6) Oil bottles
7) Assembly of solenoid valve and check valve	8) Manifold assembly 1	9) front cover (plastic)
10) Condenser and cooling fan	11) Front wheel	12) Compressor
13) Rear wheel	14) Vacuum pump	15) Side cover
16) Accessory holder	17) Back cover	18) LCD display
19) Pressure gauges	20) Printer	21) Drier-filter
22) Manifold 2		

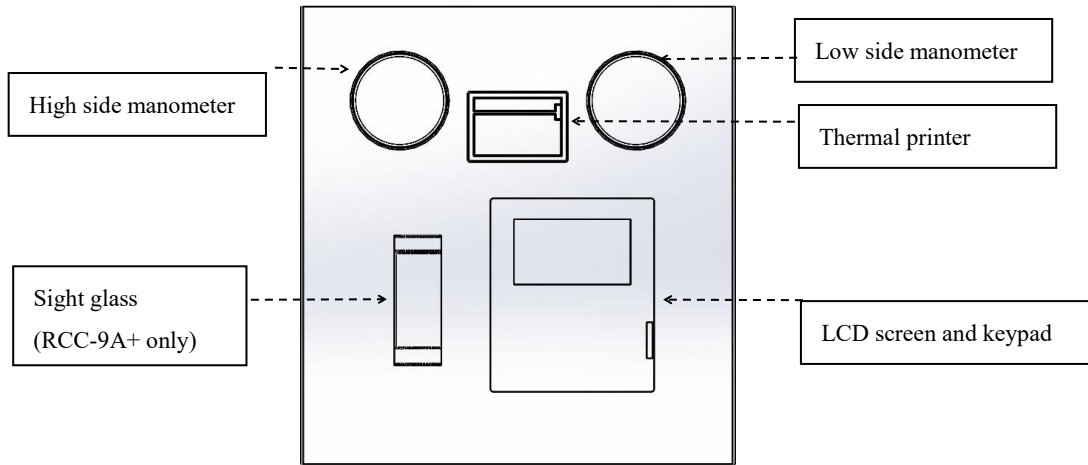

Control panel

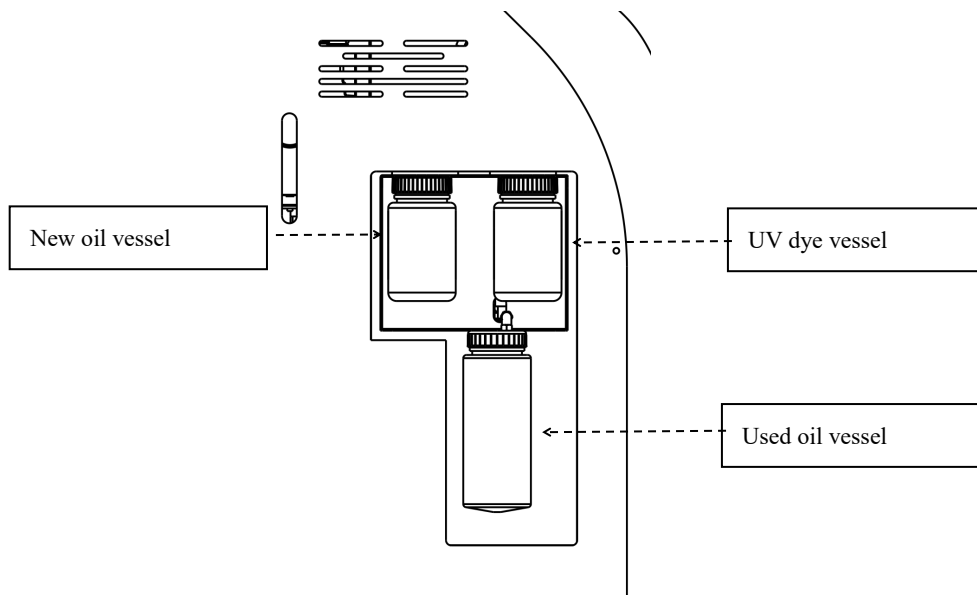

Left view

Function description

Main functions	Recovery	Recovers and purifies refrigerant from automotive A/C system and it is then stored in to the machine internal storage cylinder for re-use.
	Evacuation	Removes air,debris and moisture from the vehicle A/C system, <i>with electronic vacuum leak detection test as optional function.</i>
	Oil/dye injection	Electronically injects the preset or selected amount of oil and/or dye into the vehicle A/C system.. <i>UV dye injection is optional.</i>
	Charging	Electronically charges the selected amount of refrigerant in to the vehicle A/C system
	Tank fill	Transfers liquid refrigerant from an external cylinder to the machine internal storage cylinder.
	Flushing (RCC-9A+ only)	With this unique flushing system, the machine will extract all compressor oil from automotive A/C system. Since A/C additives (such as UV dye, leak stopper and cooling booster) and contaminants (moisture, metal and rubber particles etc.) are mainly mixed or dissolved in compressor oil, flush is very important not only for A/C routine maintenance, but also necessary when an A/C part is replaced.
	Fully automatic function selection	The machine will perform all the selected functions in a fully automatic sequence. The machine will stop automatically once all the selected functions or function have been completed.
System. settings	Language	Selecting language.
	Calibration	Calibrate refrigerant cylinder load cell, oil vessels load cells, pressure transducer and temperature sensor.
	Vehicle database	The machine stores a large number of vehicle makes and models, with manufacturers' recommended refrigerant and oil charge quantities.
	Unit settings	Selecting metric or imperial units of measurement. All sensor values displayed in this interface for equipment diagnosis purpose.
	Tare weight setting	Set empty refrigerant cylinder or refrigeration oil zero (tare) weight.

Preparations before operation

1. Unlock tank load cell

Unlock the load cell , by removing the safety locking **bolt** as shown below and save the bolt for future use.

PLEASE NOTE, whenever transporting the machine, re-fit the safety locking bolt to avoid damage to the load cell.

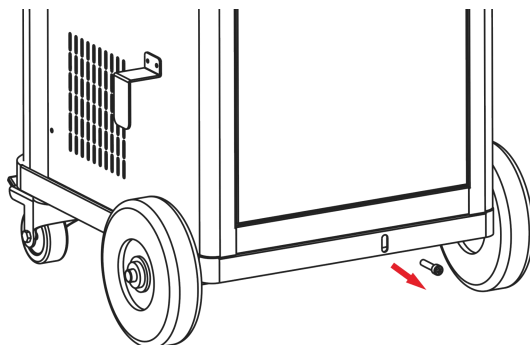

2. Tank fill

Use the adaptor fitting, to connect either HP or LP service hose (red or blue) to external refrigerant cylinder **liquid port** which you will be transferring the refrigerant from. If the refrigerant cylinder has only, **One valve and one port**, invert the cylinder as shown below. If the cylinder has, **Two valves one port**, leave the cylinder upright and open the liquid valve only, if the cylinder has, **Two valves and two ports**, connect the adaptor to the liquid port, leave the cylinder upright and open liquid valve on the cylinder. Set the amount of refrigerant to be transferred into the machine storage cylinder, once the selected amount of refrigerant has been transferred, the machine will instruct the technician to close the liquid valve on the external cylinder. The machine will then recover the remaining refrigerant in the service hose which is connected to the transfer cylinder and it will then stop automatically. For more details please refer to “Tank fill” in the operating procedure chapter.



3. Non-condensable purge

If you machine is not equipped with automatic air purge, you will find manual air purge valve at equipment side, shown as picture below. Please refer to Pressure-temperature chart and tank pressure, turn the valve purge the non-condensable till proper pressure is obtained in the tank.

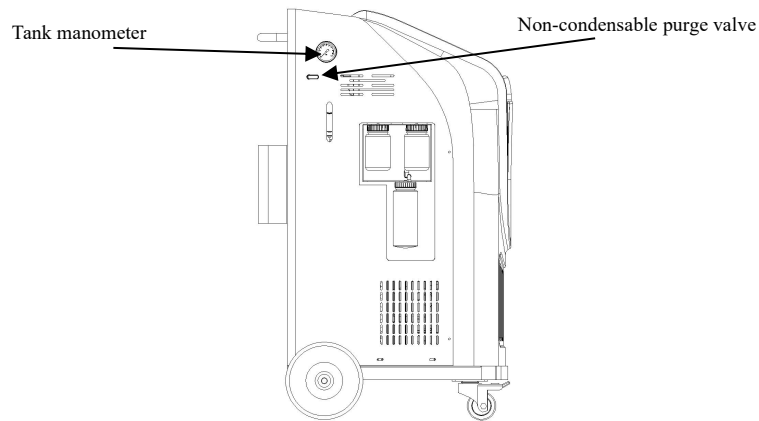

Operating procedure

Recovery function

For HFO-1234yf system, refrigerant identification is necessarily processed. Only when the purity of refrigerant is above 98% the recovery is allowed.

Check and empty the used oil vessel before the recovery process is initiated.

The recovery process removes refrigerant from the vehicle A/C system, until a vacuum is reached. During this process, the refrigerant is purified from any moisture, oil and foreign particles. The processed refrigerant is then stored in the internal storage cylinder of the machine, ready for re-use. If any oil is recovered during this process, the oil will be discharged into the used oil vessel. After the first recovery has been completed, the machine will pause for 3 minutes, to check if there is any refrigerant left in the vehicle A/C system. Recovery will start again automatically if there is a pressure rise during the 3-minute pause. At the completion of recovery, the machine will display and print the total amount of refrigerant recovered and oil if any.

Evacuation function

Select “**Vacuum**”, evacuation is performed to further remove air and moisture from the vehicle A/C system, making it ready for oil injection. Evacuation time can be set from 2 to 60 minutes. If the machine has vacuum leak test function, vacuum test can be selected to effect 10 minute vacuum leak test.

Oil injection function

Select “**Oil injection**”, set oil volume and new oil is sucked into A/C system by vacuum created by vacuum function.

UV can be also selected to inject UV dye for future leak detection.

If the vehicle A/C system is not in a vacuum state, oil or dye injection can not be performed and the machine will display a warning.

Hose flush, if hose flush is selected (highly recommended), the process will flush the oil from the wall of the service hoses and internal pipelines, to make sure the new oil to be injected is not contaminated with the previous oil injected or recovered. This process will take about 5 minutes.

Refrigerant charging function

Refrigerant charge amount can be set by the technician, or by selecting car make and model in the database. Refrigerant can be charged through high side, low side or high and low side.

Note, vehicle A/C system should be switched on when charging through the low side of the vehicle A/C system.

Note, if charging is selected from high and low side simultaneously, care must be taken. After charging function is completed and before starting the engine and switching on the A/C system, turn the compressor hub several times by hand to expel any liquid refrigerant that may have accumulated in the compressor compression chambers during the charging process. **Not performing this process can damage or destroy the compressor.**

Hose purge, hose purge is selected in charge function (default), to charge the full amount of refrigerant selected. Some refrigerant will be left in the discharge hose (high side service hose) either at charge function or at A/C diagnosis with vehicle A/C on. Follow the instruction displayed on the touch screen to purge the remainder of refrigerant left in the discharge hose into the vehicle A/C system. This will make certain that 100% of the selected amount of refrigerant is fully charged into the vehicle A/C system.

Tank fill

Please note, refrigerant identification is highly recommended before transferring refrigerant in to the machine internal storage cylinder, by using a reliable refrigerant identified.

Select **Tank fill** to fill or add refrigerant into machine storage cylinder. It is recommended to maintain 4-6 kg refrigerant in the machine internal cylinder at all time, to guarantee better charging and flushing operations. During the refrigerant cylinder filling process the machine will display to the technician to **close hand valve on the external cylinder**, the machine will then recover the rest of refrigerant which is left in the transfer service hose and internal pipelines.

The minimum tank fill set value is 0.5kg.

The maximum tank fill set value is the calculation result of 8kg (80% of tank allowable maximum weight) minus amount of refrigerant the tank contains (For example, if there is 2kg refrigerant in the equipment tank, the maximum tank set value is 6kg).

Flushing function (only for RCC-9A+)

For HFO-1234yf system, refrigerant identification is necessarily processed. Only when the purity of refrigerant is above 98% the recovery is allowed.

Please note, empty used oil vessel before starting this operation.

Flushing function is performed to completely extract compressor oil from A/C system, thus contaminants such as acidified substances, moisture and other foreign particles will also be extracted together with oil.

During the flush, refrigerant flows in forward direction (charge liquid refrigerant from A/C low side to dissolve compressor oil, and at the same time recover from the high side) and reverse direction (reverse direction means charge from high side and recover from low side, in reverse from normal A/C flow), each direction lasts certain period of time. Flush time can be set corresponding to refrigerant amount in system. For example, A/C system with 500g refrigerant, flush time is recommended to be set at **30 minutes**, while **60 minutes** can be set for system with 1kg or more refrigerant. Flushing refrigerant will be recovered and purified automatically, at the end of the flushing process and stored in to the storage cylinder, ready for re-use.

For some A/C system equipped with evaporator solenoids or electronic expansion valves, which are normally closed when the vehicle A/C is off, it is recommended to activate the solenoid and TX valves with proper diagnostic scanner or remove and bridge these valves with the appropriate bridging fittings. Not performing the above, refrigerant flow is restricted and flushing efficiency can be affected.

For multi-flow condenser, the oil in the condenser may not be flushed out completely.

Please make sure at least 3.5KG refrigerant in equipment, or flush is not permitted to run.

Automatic function mode

Please note, empty used oil vessel before starting this operation.

In automatic function mode, the machine runs flush, recovery, evacuation, vacuum test if selected, oil injection, dye injection and refrigerant charge in sequence, with data of each operation preset by technician.

Please make sure at least 3.5KG refrigerant in equipment, or flush is not permitted to run.

Hose flush, if hose flush is selected (highly recommended), the process will flush the oil from the wall of the service hoses and internal pipelines, to make sure the new oil to be injected is not contaminated with the previous oil injected or recovered. This process will take about 5 minutes.

System Setting

Input password 111111 to enter “System. Setting”. In system setting, Language, Calibration, Database, Unit set, Empty container weight set, Component testing and owner information will be displayed or reconfigured.

Calibration: It is recommended to have professional technician only to perform calibration of load cells, pressure transducer and temperature sensor.

Warning: *Not calibrating the machine correctly can have serious consequences on the machine and/or vehicle A/C system.*

Database: The technician can access database of refrigerant, oil volume of different car makes and models.

Record: Record total operations of recovery, vacuum, oil injection and charge. Can reset to re-record. A dynamic code is needed for access.

Unit settings: To set metric or imperial unit of measurement. In the interface of “unit set”, values of each sensor of the equipment are displayed for equipment diagnosis purpose.

Empty container weight set:

The total load cell reading equals the sum of empty container weight and net refrigerant/oil content value. Thus, increase/decrease empty container weight, can correspondingly decrease/increase refrigerant/oil value displayed in the main operation interface.

Component test:

The technician can activate and deactivate different electrical component of the machine. This is for quick and easy diagnosis and troubleshooting.

Please note:

Only qualified technician (with special password) is allowed to access this function, not performing this test correctly could cause damage to the machine or injury to the operator.

Caring for your equipment

- Keep your equipment clean and well maintained at all times.
- Keep service hoses stored on the storage adapters when not in use, to avoid dirt and dust contaminating the internals of the couplers which will then end-up in the vehicle A/C system, which can cause serious system malfunction.
- Always clean vehicle A/C system service ports before connecting machine quick couplers on to the service ports.
- Keep the system stored in a clean area and away from direct sunlight and artificial heat source, when not in use.
- Perform regular services on the system as recommended by the manufacturer. Ignoring and skipping services will deteriorate the integrity of the machine.
- If the machine is used on badly contaminated A/C systems frequently, it is recommended that more frequent vacuum pump oil changes are made and main filter replacements are performed. Contaminated vacuum pump oil will cause the vacuum pump to corrode badly internally, which eventually the vacuum pump will fail. Contaminated main filter will diminish the refrigerant purity.
- Do not bump or move the machine when the technician is in the process of charging a vehicle, this can affect the charging accuracy.
- If the machine is bumped or knocked down accidentally, check the calibration and that there are no leaks internally.
- **DO NOT** use compressed air to test for leaks.
- If the technician is not sure on the correct way of operating the machine, please do not hesitate to contact your distributor or manufacturer. We always like to help you.

Update



Pressing → and ← keys, turn on the machine.

The machine displays the following message.



Connect the machine with PC through USB port. In PC, run USBload.exe, the PC displays the following message:

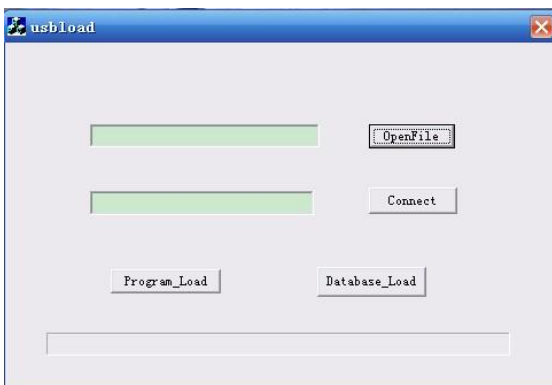

Click “OpenFile” to select update to update, e.g. file “RCC8A_V2.01” (for main program update) or “Database_V2.02” (for database update). Then click “Connect” the PC displays the following message

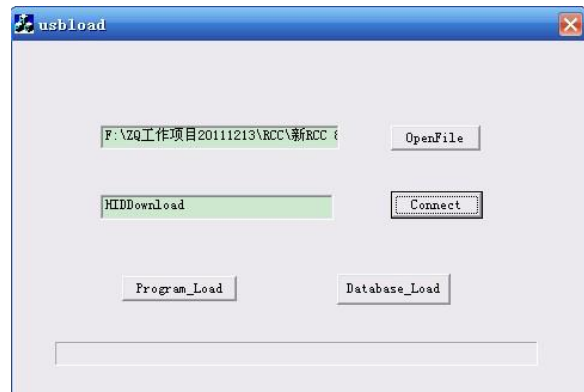

Click “Program_load” for main program update, or click “Database_load” for database update, the machine displays the following:

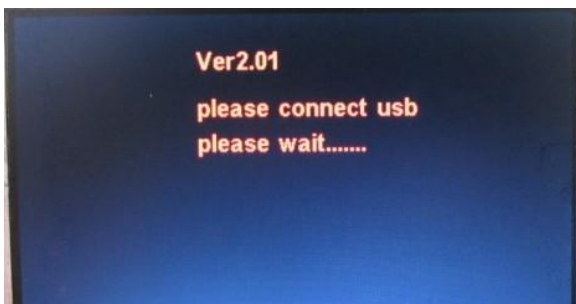

In about 1 minute, the machine displays:

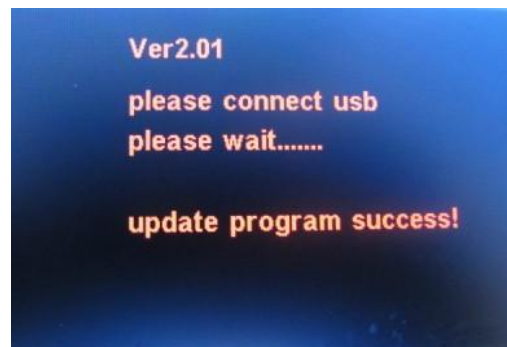

Turn off the machine and turn it on again, the machine will run the updated software.

Maintenance reminding

The machine permits totally 600 operations (every recovery or vacuum counts for 1 operation, and one automatic operation counts for 2 operations) before service/maintenance is forced to make. The remaining operation number is displayed when machine turns on.



Upon 480 operations having been made, the machine displays the following message, and users can continue using the equipment meanwhile make distributor appointment



Upon 600 operations having been made, the machine will display the following message while the machine stops working. Maintenance has to be made to reset service interval time again.

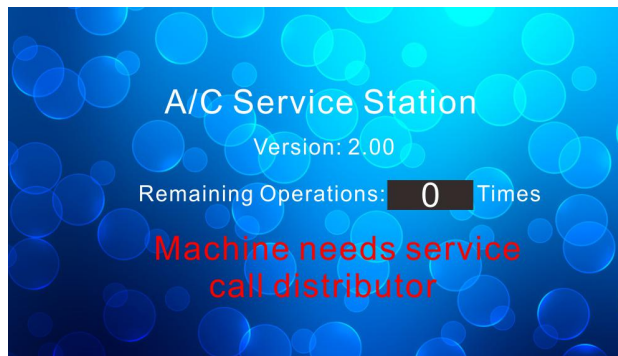

Packing list

Part Number	Article	pcs	Package
ZT010017	RCC-8A+ main unit	1	
ZT010019	RCC-9A+ main unit	1	
BZ030017	3m red service hose	1	
BA030016	3m blue service hose	1	
BZ130037	HP quick coupler	1	
BZ130038	LP quick coupler	1	
DZ160033	30A fuse	1	
DZ180034	Update cable with USB	1	
WJ010007	HP/LP block cap	2	
BZ130026	Tank fill fitting (R134a)	1	
BZ130027	Tank fill fitting (R1234yf)	1	